

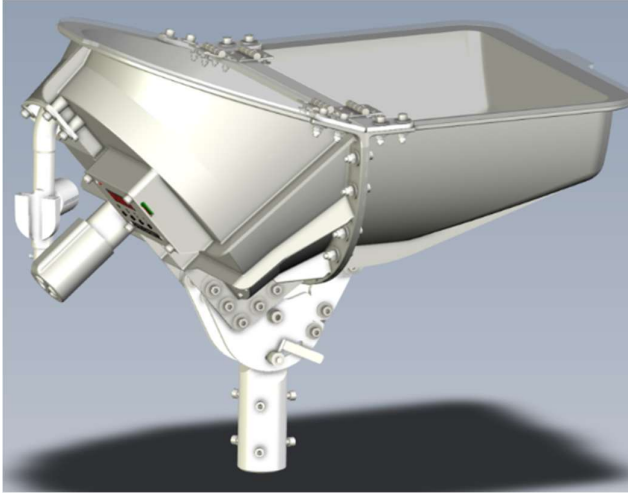

Casefeeder Operating and Maintenance Manual



PLEASE READ THIS MANUAL BEFORE ASKING FOR TECHNICAL SUPPORT

We are always happy to help if you have any questions, but it's nice to know you have read this manual first. It will help if you can use the same words / terminology to describe parts as well when talking with us.

We strongly recommend joining the OFFICIAL ROLLSizer.COM Facebook Forum. (You will need to agree to the terms of joining to be accepted). We will be posting updates and information about the casefeeder and operation, particularly the additions to calibre conversions.

The present shellplate supplied with the casefeeder is designed for pistol (380ACP up to 45ACP) at high throughput, it will process small rifle (223 and 300BLK) but at much slower rates. The pistol cases (9mm, 38S/SC, 40S&W and 45ACP) will process at 10k per hour.

Please note, no casefeeder in existence is jam proof, the casefeeder is highly resistant to jamming but we recommend you play with the adjustments (program speed and tilt angle) and fill amounts in the casefeeder first. Please follow the manual for setup and read the manual from start to finish.

The casefeeder has been designed for operation with clean or lightly soiled cases (for processing through our decappers), but there are limits, rocks and 0.22 cases will jam anything. We recommend some form of cleaning to remove rocks and the like.

The casefeeder should always be cleaned thoroughly before feeding a rollsize.

The Commercial Casefeeder comprises of 2 parts. The Casefeeder and the Hopper are supplied and shipped in separate boxes and requires some assembly (mounting post and the hopper extension).

The Standard Casefeeder requires some minor assembly to assemble the mounting post.

Please note, minor scratches and marks occur in fabrication and transportation process and are not considered a warranty item.

The use and operation of the Rollsize is subject to the Terms and Conditions available on the ROLLSizer.COM website.



Contents

Introduction	3
Safety First	4
Disclaimer.....	4
1. What is supplied with the Casefeeder	4
2. What is supplied with the Hopper Extension?.....	7
3. Casefeeder Adjustment	7
4. Casefeeder Throughput	9
5. Control Panel.....	10
6. What happens when there is a jam?	11
7. Mounting arrangements.....	13
8. Casefeeder Maintenance	14
8.1 Pre-start inspection.....	14
9.0 What Tools do I need?	14
9. How to contact us at RollSizer.com.....	15
10. FAQ's.....	15



Introduction

Please ensure you read this manual from start to finish **BEFORE** you use the RollSizer. Please pay attention to the following key points.

- The Casefeeder and Hopper assembly is made of Injection moulded parts using a high grade, wear resistant and very strong engineered plastic composite.
- The clear plastic lids and front panel is made from Polycarbonate and extremely durable. The lids will reduce noise and dust emissions.
 - ❖ *As a basic rule, if your cases are touching the LID, especially the Casefeeder lid, the casefeeder is too full.*
- The Commercial Casefeeder is made up of 2 parts, the (Standard Casefeeder + Hopper Extension).
- Some assembly is required for the Casefeeders using hand tools (not supplied but detailed in the document below).
- The casefeeder has been designed with the following controls
 - On / Off buttons, controlled by pressing the P button
 - Variable speed casefeeder motor with the + / - buttons on the control panel.
 - Automatic shutoff in the event of overloads. Overload is reset by pressing the S button twice in quick succession.
 - Automatic start / stop when the case tube fills and reaches the proximity sensor. The motor will restart with a 3 second delay after the cases clear the proximity sensor.
 - Steel case detection (using the automatic start / stop) when a magnet is installed in the magnet slot.
 - Case Count (when turned on).
 - Case Count Stop ((when turned on).
- The drop chute / hose connector is a twist lock unit and allows the casefeeder hose to be disconnected from the case feeder (for clearing jams or emptying the Casefeeder / Hopper).
- The supplied clear hose is to join the Aluminium connector to your press or rollSizer. The hose is a thick wall Vinyl tube and the end needs to be heated in boiling water to soften the end to stretch and screw onto the hose end.
 - ❖ *The casefeeder hose MUST be disconnected from the Drop Chute before changing the casefeeder position. Failure to do so may result in the drop chute being damaged.*
 - ❖ *Please check the fitment of the hose connector to the drop chute before fitting the drop chute to the tub, the connector should fit onto the drop chute easily. If it does not the Aluminium connector may need some filing / to clear the fitting. If this occurs, please contact us for methodology.*
- Any modifications to the Casefeeder or Hopper will void the warranty, if you have a question about the RollSizer or its operation, please ask us.
- RollSizer.com products are sold subject to the terms and conditions detailed on the website. Refer to <https://www.rollSizer.com/terms-and-conditions/>



Safety First

Please note that with all machinery, your safety is critical. Do not allow inexperienced users to access or operate this machine and never allow children or minors near this machine whilst it is operating. Never attempt any sort of work or adjustment on the machine whilst the machine is energized or operating. Work should only be done on machinery when the power supply is turned off and the power lead is unplugged from the power supply.

Failure to do this could result in significant injury or death as a consequence.

In addition, you should never process reloaded ammunition or cases with live primers through RollSizer.com machinery, if the ammunition or components are ignited, there is significant risk of injury or death as a result.

The Casefeeders can be heavy and can exceed 18kg (40lbs) and should be handled with care to prevent injury to yourself or others.

Disclaimer

The purchaser and users of this machine expressly acknowledges and hold harmless RollSizer.com Pty Ltd, PAHK Holdings Pty Ltd, its affiliates, associates and resellers (hereafter noted as RollSizer.com), from all liabilities including loss of income, injury, harm or death for the use of the RollSizer and any actions that the use of the RollSizer may have.

All RollSizer.com Pty Ltd products are subject to the terms and conditions detailed on the rollSizer.com website.

1. What is supplied with the Casefeeder

The Standard Casefeeder is supplied with the following parts fully assembled;

- Injection moulded tub assembly with fitted lid, front cover and pistol calibre shellplate.
- Integral high quality planetary drive assembly with a fitted drive nut.
- Control panel which is wired to the drive assembly.
- Aluminium mounting plate bolted to the underside of the casefeeder

The following parts are supplied loose within the tub assembly; These are required to be mounted as required. The tool requirements listed below are not supplied but are not expensive.

- Mounting post with an M8 bolt, nut and washers (requires 6mm allen key and a 13mm wrench)
- 12VDC universal AC / DC power supply with a 2.1mm x 5.5mm power connector. (The 12V outlet plug is a standard with the centre pin as +ve). This plug uses an adaptor to plug into a wall socket. The power supply will run off all voltages between 100VAC up to 250VAC (50 or 60hz) with no problems. When your feeder was purchased you nominated a voltage and this determines the plug type provided. The power plug fits into the power plug socket on the control panel.

- ❖ **BEFORE YOU PUSH THE POWER LEAD IN MAKE SURE IT IS THE RIGHT SOCKET. PUSHING THE POWER PLUG INTO THE PROXIMITY SENSOR SOCKET WILL DAMAGE THE SENSOR PINS AND IS NOT A WARRANTY CLAIM. Refer to the photos in this manual to confirm the right plug.**



- Drop Chute assembly with a fitted proximity sensor. The drop chute assembly is required to be bolted onto the underside of the casefeeder tub with the 4 x M6 socket head bolts fitted to the tub. The M6 socket head bolts require a 5mm Allen key. This should be fitted before mounting the sensor lead. The sensor is held into the drop chute with a cable tie. The end of the electrical lead is fitted with a 3 pin connector. The connector lead has a 3 pin connector that requires careful fitting before screwing the retention cap.
- Aluminum twist lock adaptor and length of clear vinyl hose.

Refer to the Photograph below for more information.

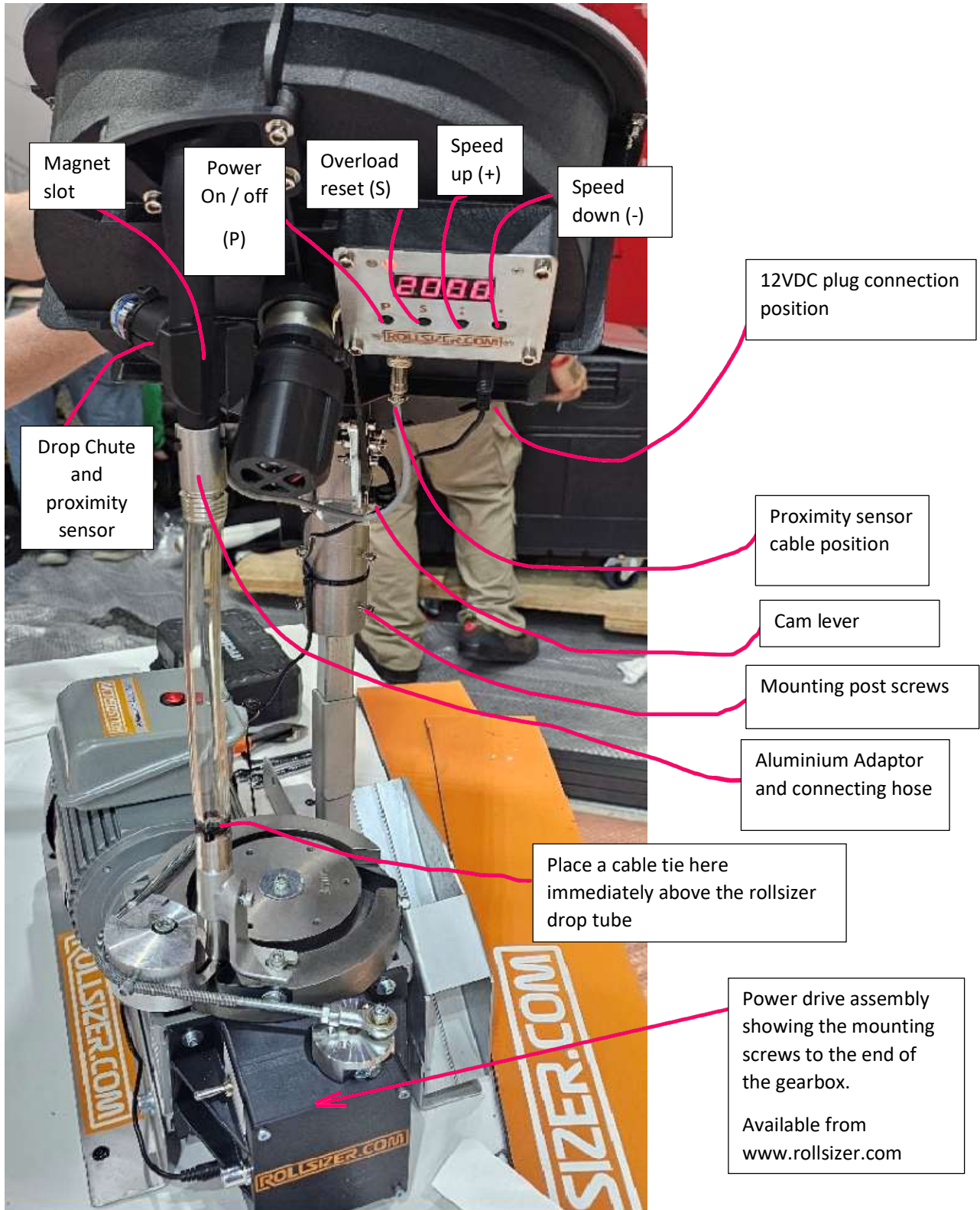

2. What is supplied with the Hopper Extension?

The Hopper extension is supplied with the following:

- Injection molded hopper assembly with fitted lid and hinge mechanism. A small bag comprising of some aluminum plates and fasteners is cable tied to the underside of the hopper. The diagram below shows how the brackets / bolts are secured. All fasteners are M6 Socket head screws and require a 5mm Allen key and a 10mm open end Wrench.
- When mounting the Hopper Extension to the Casefeeder, the clear front panel of the Casefeeder unit is required to be removed. The same screws are used to mount the Hopper Extension. All Fasteners should be installed with washers and Nyloc nuts finger tight only BEFORE tightening.
 - ❖ We recommend you use / purchase a 100mm long 5mm BALL End T-Handle for this job. Alternatively, a 5mm Ball end Allen Key x 50-100mm long with ¼" drive is an alternative and you can use a small drill. Do not use impact function and only lightly tighten the fasteners, they are all supplied with Nyloc nuts and washers and should NOT be overtightened.
- These brackets must be installed to ensure the hopper extension is properly supported. It is recommended that all the bolts are fastened loosely in position before tightening

3. Casefeeder Adjustment

The casefeeder has been designed to be adjustable in 3 areas.

- The mounting post position (in plan view)
- Casefeeder angle of the Shellplate
- Operating Speed of the Shellplate (the motor speed has a minimum speed of 1,000rpm up to 3,400rpm.

1. The mounting post has a 36mm hole and will accommodate most existing press casefeeder mounts (typically 25mm Square tube / 1") or round tube up to 36mm in diameter. The mounting tube is fitted with 6 x M6 Socket head screws placed at 1/3rd positions (when seen from plan view). This is deliberate and allows for the secure mounting and alignment of the drop chute to the required point. By using the Screws to lock onto a flat / angled face of the square tube, the Casefeeder alignment can be secured to suit most applications. The Casefeeder design has been set up to mount to the Commercial RollSizer mounting post and drop the cases to the required point. Refer to the picture below.

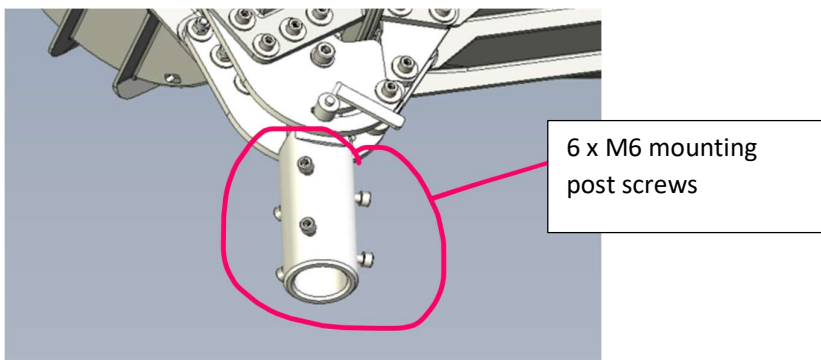

2. The casefeeder shellplate angle was designed to be adjustable. With testing and experimentation, experienced users will determine their optimum angle for adjustment. However, as a starting point, the Casefeeder should be mounted as shown below.

- Leaning back (Lifting the hopper above vertical) will increase the throughput but will pull cases further up the Shellplate resulting in jams and upside-down cases.
- Lowering the Hopper below vertical will reduce the casefeeder throughput and reduce the ability to feed cases from the hopper into the casefeeder.

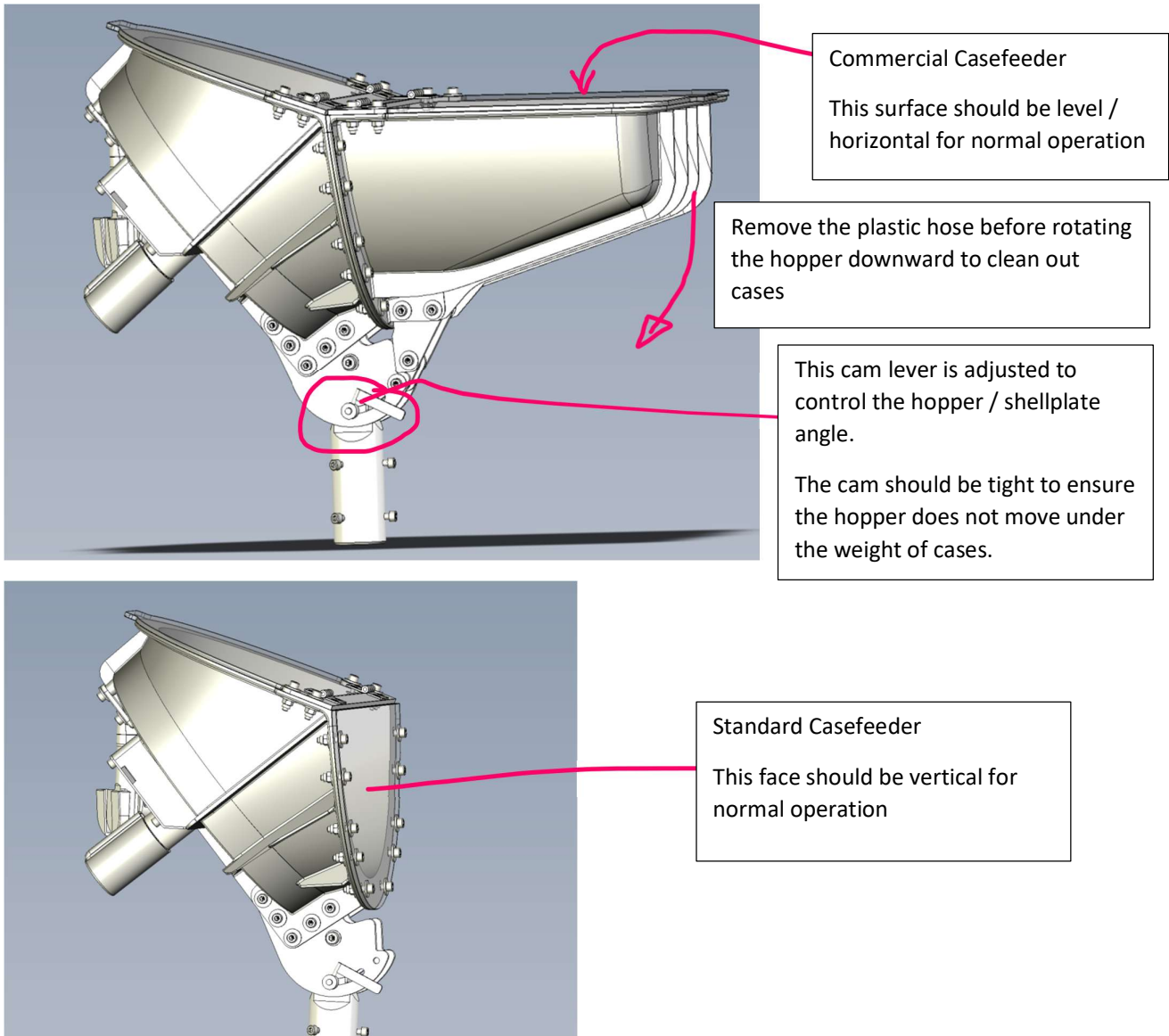



4. Casefeeder Throughput

The casefeeder throughput is generally independent of the load of cases and but will vary depending on the case type. The small pistol cases such as 380ACP, 9x19mm, 38S/Supercomp, 40S&W and 45ACP will supply and hold an average throughput of 10,000 cases per hour.

As a general rule, we recommend running the motor speed between 2,800 up to 3,400rpm to maintain case trajectory for the 380, 9x19, 38S/SC, 40S&W and 45ACP.

The longer pistol cases such as 38SPL, 357Mag and 44Mag will have reduced throughput (generally up to 6,000 to 8,000 cases per hour).

The 223 and 300BLK cases can be fed through the casefeeder but at substantially slower motor speeds (generally no more than 2,000rpm). The running faster than this will not help as the drop chute will not allow the longer cases to clear through the drop chute. When the high-volume small rifle shellplate is released, it is expected to include a drop chute to suit the rifle cases.

- ❖ *The motor operating speed is adjustable and can be set using the +/- buttons. The actual motor speed will vary according to the actual load on the shellplate / hopper load.*













For example, the motor speed may be programmed at 3,200rpm but will run at 2,600rpm. This will progressively increase as the shellplate / hopper case load decreases. This is deliberate and is part of the process to maintain the casefeeder throughput as the shellplate load runs down.







We expect to be releasing a Small Rifle Calibre conversion (223 and 300BLK) around 2nd Qtr. 2026. The throughput is yet to be confirmed, but we are hoping to achieve closer towards 8,000 Cases per hour. We currently have 5,000 cases per hour in prototypes.

The Large Rifle conversion will be 3rd Qtr. 2026. Throughputs are yet to be confirmed.

- ❖ *Please note, the RollSizer.com power drive is an excellent way of utilizing the increased throughput of the casefeeder when feeding our Commercial RollSizer. The power drive will increase the Commercial rollSizer from around 6,400 cases per hour up to the limit of the casefeeder. This bolts directly onto the end of the Commercial RollSizer gearbox and removes the need for levers and bolts (It's also REALLY quiet).....*
- ❖ *The Power Drive will process up to 14,000 cases per hour and should not be run at 100% speed. When we developed the power drive, we did not have the casefeeder in production and did not balance them.*

5. Control Panel

	Icon	Description
		DC12V Power LED
		4-bar screen
		Motor ON/OFF set and parameter function
		Motor reversal set and parameter function
		Plus
		Minus

- When the power is connected the control panel, the DC12V Power LED  will be illuminated.
 - To start the casefeeder, press the  button once. To stop press the  button again.
 - To reverse the casefeeder motor press and Hold the  button for 2 seconds. The motor reverse will stop when the button is released.
 - To increase the motor speed, press the  button. Holding the button down will increase the speed in larger amounts. The motor speed preset is 1,000rpm up to 3,400rpm.
 - To decrease the motor speed, press the  button. Holding the button down will decrease the motor speed in larger amounts.
 - To reset after a fault code, press the S button twice in quick succession and the relay will reset (for E-03 and E-04 Error codes).
 - When a case passes the proximity sensor the sensor light will flash. The motor will only stop when a case is present due to a full tube or because a steel case has been caught by the optional magnet. A STOP message will appear on the panel automatically.
 - When the tube clears, the motor will restart 3 seconds after the case clears the sensor.
- ❖ There are a number of parameters set from the factory and are not able to be changed. These parameters are password protected to ensure the motor and overload protections are in place. Changing these factory set parameters will immediately void the warranty and all parameter changes are logged in the control board.



The Control panel will occasionally display the following Error codes. These can be cleared by pressing the  twice in quick succession.

Fault & Warning Code Table

Fault & Warning code	Description
E-01	12VDC over-voltage protection.
E-02	12VDC under-voltage protection.
E-03	Motor over-current protection.
E-04	Motor stall protection.
E-05	Motor overload protection.
Stop	Pipe blockage.
	The count value reaches the number set





As a general rule you will only see the E-03 and E-04 overload messages

5.1 CASE COUNT

The case count / case count stop parameters are able to be turned on / off and set as follows.

With power on, a press and hold  to enter / access the count function parameter settings (no password is required). The setting method is the same as above. The related parameters for the count function are P030, P031 and P032.

The Case count parameter is defined under P030 and is normally turned off (Default).

- When the P030 is set to 1, the count function is enabled.
 - When a metal object passes quickly by the sensor, the count will increase by 1. The main interface cycles display “SPD → Speed → CNT → Count value”.
 - Press  to quickly switch between “SPD” and “CNT.” When speed is displayed, it can be adjusted using  and ; when the count value is displayed, it can be adjusted using  and .

5.2 CASE COUNT STOP

To enable Case Count Stop, the Case Count P030 must be set to 1 first.

The Case Count Stop is enabled when P031 is set to 1, the count stop function is activated. (P031 default is 0).

- The Case count Stop number is defined in P032, the count stop number can be anywhere between 1 and 9,999 (the limit of the digital panel).
 - When the count value reaches the number set in P032, the machine will automatically stop and display 'STOP'. At this time, 2 x presses of  in quick order to clear the count value and restart the operation.







6. What happens when there is a jam?

No matter the design all casefeeders can be jammed if the wrong cases / contaminated material is put in the casefeeder. Examples of this would be rocks, 0.22 cases, tumbling pins, loose primers etc. All can jam a casefeeder



given the right conditions. The Casefeeder has generous trash slot to remove most material (primers, cleaning media etc).

There are a few different overload conditions and the casefeeder reaction will depend on how the jam effects the casefeeder.

- Minor jam.
 - An example of this would be if a 0.22 case was caught under the shell plate. The normal reaction for this would be to automatically detect an excess drag on the motor and an automatic reversal would occur. The reversal would occur a few times to potentially clear the jam.
 - If the jam does not clear, the motor will stop and display an error message E-03.
 - The E-03 error can be cleared by pressing the  button on the control panel twice, in quick succession. A small click can be heard in the control panel and the panel will reset.
 - If the jam is still there, the operator can press and hold the  button and the Shellplate will reverse slowly allowing the operator to access the case / cause of jam and remove
 - Once the jam is cleared, the operator presses the  button and the casefeeder restarts at the same speed as before.
- Medium jam
 - An example of this would be running at slower speeds (normal reloading) and a case jams the discharge chute. When this occurs an E-03 error will show. The operator investigates and removes the offending case / cause.
 - The E-03 error can be cleared by pressing the  button on the control panel twice, in quick succession. A small click can be heard in the control panel and the panel will reset.
 - The operator presses the  button and the casefeeder will start normally
 - ❖ In situations where the casefeeder is running in an overloaded condition, the cases will carry over the and hold the cases in a tilted condition. In this situation the cases will jam repeatedly. Remove some of the cases from the shellplate area and restart.
- Major jam
 - An example of this would be running high speed and a case jams in the Shellplate (a damaged case would be a good example). The casefeeder plate will stop suddenly and an overload message E-04 will occur.
 - The E-04 error can be cleared by pressing the  button on the control panel twice, in quick succession. A small click can be heard in the control panel and the panel will reset.
 - The operator presses the  button and the casefeeder will start normally.

In situations where the shellplate cannot be reversed, the shellplate can be manually moved if required.

- ❖ The planetary drive was selected for specifically this situation where a manual reversal would not damage the gears / gearmotor.

7. Mounting arrangements



What is the route of the flexible hose between the casefeeder and the RollSizer? The hose route needs to be smooth without kinking the hose.

- Is there clearance at the back of the RollSizer for the cooling fan to operate correctly?
- Can you access the center bolt holding the caliber conversion disc in this position to allow you to do caliber conversions without moving the RollSizer?
- Can you see the cases under the drop tube to check the drop tube is adjusted to the correct height?



- If you are in doubt ask us, we are here to help, we reload ourselves, so we do actually understand the placement issues.

❖ **It cannot be emphasized enough; you must limit the RollSizer processing rate to match the AVERAGE casefeeder performance.**

8. Casefeeder Maintenance

The equipment requires very little maintenance, the majority of maintenance will be related to the following;

1. Remove the shellplate disc and wipe out vacuum out any residual dirt inside the casefeeder.
2. Check / verify the drive nut inside the casefeeder is secure and that the grub screws are tight. If they do loosen, remove the grub screws with a 2.5mm allen key (not supplied) and reinstate the drive nut with medium strength locktite on the threads and inside the drive nut housing.
3. Check the overcentre clamp holding the casefeeder angle is tight and adjust as required.

Should the electric motor stop working or trip out and electrical circuit breakers or safety fuses please do not use the machine, remove the power lead from the wall socket and ensure the machine is not used, place an “Out of Service” tag on the machine if available.

Contact us at RollSizer.com using the contact details below.

8.1 Pre-start inspection

Prior to use, the following checks should be done.

- Visual inspection, check the power lead is in good condition with no damage or marks and is clear of any rotating equipment, check the connecting hose is straight with no kinks.
- Check the power supply is safe and circuit breakers are functioning correctly.
- The gearbox does not have any oil leaks.
- When the power supply is turned on, the illuminated light on the control panel box is illuminated.
- The case feeder is clear of cases and is operating in accordance with the manufacturer’s manual.

9.0 What Tools do I need?

You will need the following for assembly. We strongly recommend you purchase high quality tools (buy once cry once) that will last a long time and NOT round off the bolts when tensioned.

- 5mm, 6mm Allen keys, (we recommend the 5mm Allen key be purchased as a ball end - T handle if you are assembling the commercial casefeeder).
- 10mm and 13mm open end spanners.

The following additional tools may be required.

- 2.5mm Allen key for the Drive nut.

All bolts used in the RollSizer are metric bolts. The use of imperial Allen keys will result in rounded sockets.



9. How to contact us at Rollsizer.com

Please tell us **WHERE** you are from when you contact us **WITH** a phone number. We are not mind readers, but we do actually call back. Alternatively, the Official Rollsizer Forum on Facebook will be an excellent source of information particularly when considering how to connect the hose to your press.

Phone +61-400-712-512
Email. info@rollsizer.com

Postal address Rollsizer.com Pty Ltd
P.O. Box 1017,
Roleystone, Western Australia 6111,
Australia

10. FAQ's

MY CASES ARE JAMMING.

- A. The major cause of jamming is from the use of unsorted and contaminated brass.
- B. Cases nestled inside each other (38Supercomp sits inside a 40S&W case nicely) Also processing taller cases (such as 38 Super) with 9mm cases for example will result in jams.

THE CASEFEEDER SHELLPLATE IS RUNNING BACK AND FORTH.

- A. This is a function of the overload sensor and the shellplate being too tight to the tub base. The casefeeder has been designed to have very little room between the shellplate and the base. If the clearance is tight and the retaining bolt is tight the shellplate will drag and overload. Once the contact surfaces have mated / polished between the shellplate and the casefeeder base this
- B. Loosen the centre bolt or remove the centre retaining bolt. Wriggle the disc and run as normal.

THE CASES ARE JAMMING OR FALLING OVER IN THE DROP CHUTE.

- A. The 9mm cases run best when running 2800> in motor speed. Running slower means the case trajectory is not always consistent.
- B. There MAY be a small step / lip between the casefeeder and the drop chute. This is caused due to a shrinkage difference between the injection moulded casefeeder and a 3D printed drop chute. Refer to the photograph below.



This is an inside view of the casefeeder hopper.

If you look carefully at the circled section there is a slight step

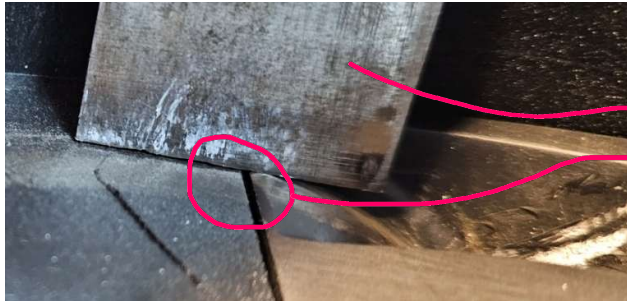

We have placed an edge of a chisel across the edge to show the step.

This ledge / step can be removed by scraping the step lightly with a sharp knife or edge of a chisel as shown below.

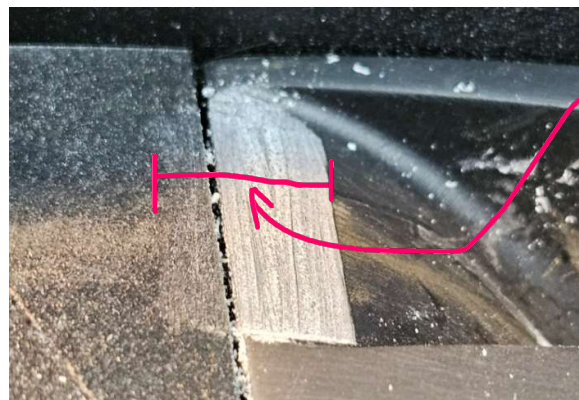

The edge here has been scraped and overlaps as shown.

THE DROP TUBE CHUTE / ALUMINIUM ADAPTOR DOES NOT FIT EASILY.

The Aluminium adaptor must be able to slide on and twist / lock onto the drop tube easily. If the adaptor has to be forced it may break the drop chute lugs

A. The adaptor fitting should look like the picture below.

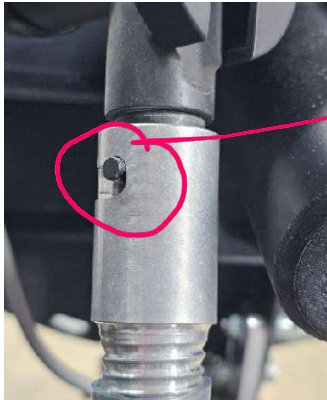

The adaptor should slide on easily and lock in the position shown.

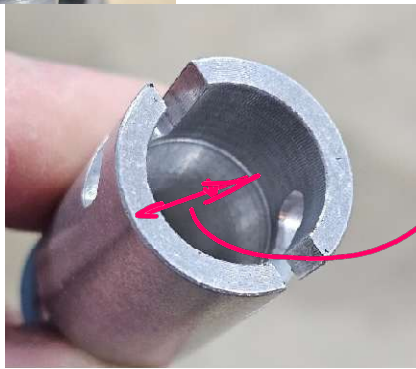

The inside of the drop chute needs to be clearanced with a dremmel or sandpaper attached to a drill.

10.5 HOW DO I CONNECT MY CASEFEEDER HOSE TO MY PRESS?

Please consult the Official RollSizer.com forum on Facebook. We will be providing an opportunity for various solutions to be offered by customers, to customers for use. The solutions may be in the form of 3D printed files and or other ideas of how people have made it work for them. These will be added as customers update their installation.

End of Document.